

# GreatHearts

Northern Oaks



## Supplemental Packet

May 18 - 23, 2020

5th grade

Ms. Carrigee

Ms. Sims

Mrs. Conrad

Mr. Eberlein

Ms. Franzmann

Student Name: \_\_\_\_\_ Section: \_\_



# Table of Contents

Letter to Parents

Weekly Schedule

Monday Reading

*Where the Red Fern Grows*, Ch. 17

Tuesday Reading

*Where the Red Fern Grows*, Ch. 18

Wednesday Reading

*Where the Red Fern Grows*, Ch. 19

Thursday Readings

*Where the Red Fern Grows*, Ch. 20

Math Answer Key for Monday - Thursday Independent Practice



# Letter to Parents

Dear parents,

Congratulations to you and your students on your progress through distance learning! Parents, we could not do it without you.

This is our review week and the structure will be a little different. We have already finished History, Science, and required work in Latin for the year. This week we will only work on Literature and Math.

For Literature, we will finish reading *Where the Red Fern Grows* and your student will choose one of four options for a simple literature project to be submitted for a grade at the end of the week. For Monday through Thursday, we will read one chapter a day, answer 4- 5 brief questions about the reading, and work 20 minutes on the literature project. On Friday, you will submit the project, with a revising and editing checklist, in place of a graded review.

For math, we will review adding positive and negative integers, graphing a linear equation, and solving for an unknown angle in a triangle or quadrilateral. There will be a graded review on Friday.

The following week will be a week for enrichment and catching up on late packets. Our specials teachers for Music, Art, P.E., and Latin are preparing some optional enrichment activities for your students.

Each homeroom will have a Literature Celebration for *Where the Red Fern Grows* Thursday, May 28th. Please check your emails for an invitation from your student's homeroom teacher. Also in week ten, a winner for the house cup will be announced in a video of the end of year house ceremony.

Thank you to each and every one of you for your courage and perseverance in our distance learning journey! We miss our students to pieces but we are proud of their progress and hope to see them walk the halls as fine young sixth graders.

Best regards,

Miss Carrigee

Miss Sims

Mrs. Conrad

Mr. Eberlein

Miss Franzmann

Miss Kelly

Miss Milligan

## *SEVENTEEN*

**L**OOKING UP THE SKY, PAPA said, "That doesn't look good up there. I think we are in for a storm."

The sky had turned a dark gray. Fast-moving clouds were rolling through the heavens.

Grandpa said, "Looks like we're going to get some wind, too."

Scared and thinking everyone might want to stop hunting because of a few clouds, I said, "If a storm is brewing, it's a good night to hunt. All game stirs just before a storm."

Thirty minutes later, Papa said, "Listen."

We stood still. A low moaning sound could be heard in the tops of the tall sycamores.

Grandpa said, "I was afraid of that. We're going to get some wind."

We heard a rattling in the leaves and underbrush. It was beginning to sleet. The air turned cold and chilly.

From far downriver, we heard the deep baying of a hound



on a trail. It was Old Dan. Seconds later, the rhythmic crying of Little Ann could be heard. Swallowing the lump that had jumped up in my throat, I whooped as loud as I could.

The ground was turning white with sleet. The storm had really set in. We hurried along.

I said to Papa, "If this keeps up that old coon won't run long. He'll head for his den."

"If it gets much worse," Grandpa said, "I know some coon hunters that won't be running very long. They'll be frozen too stiff to run."

The judge asked if there was any danger of getting lost.

"I don't know," Papa said. "It's all strange country to me."

My dogs' voices sounded far away. I knew they were much closer than they sounded as they were downwind from us. Finding three large sycamores growing close together, we stopped on the leeward side.

Papa shouted above the wind, "I don't know if we can take much more of this."

"It is bad," Grandpa replied, "and it looks like it's going to get worse."

"You can't see over fifteen feet now," the judge said. "Do you think we can find the buggy?"

"I think we can find the buggy all right," Papa said.

I could no longer hear the voices of my dogs. This had me worried. I didn't want to leave them out in the storm.

"Can anyone hear the hounds?" Grandpa asked.

"I can't," Papa said.

The judge spoke up. "Fellows, I think we'd better go in," he said. "There's no telling where they are. They may have crossed the river."

Scared and knowing I had to do something, I said, "They're closer than you think, probably treed by now. You can't hear them for this wind." I begged, "Let's go a little further."

There was no reply and no one made a move to leave the shelter of the trees.

Taking a few steps, I said, "I'll take the lead. Just follow me."

"Billy, we couldn't find them," Papa said. "You can't see or hear a thing. We had better start back for camp."

"I think so, too," the judge said.

At this remark, I cried, "I've been out in storms like this before, all by myself. I've never left my dogs in the woods, and I'm not going to now, even if I have to look for them by myself."

No one answered.

"Please go just a little further," I begged. "I just know we'll hear them."

Still no one spoke or made a move to go on.

Stepping over to my father, I buried my face in his old mackinaw coat. Sobbing, I pleaded with him not to turn back.

He patted my head. "Billy," he said, "a man could freeze to death in this storm, and besides, your dogs will give up and come in."

"That's what has me worried," I cried. "They won't come in. They won't, Papa. Little Ann might, but not Old Dan. He'd die before he'd leave a coon in a tree."

Papa was undecided. Making up his mind, he stepped away from the tree and said to the others, "I'm going on with him. You fellows coming, or going back?"

He turned and followed me. Grandpa and the judge fell in behind him.

By this time the ground was covered with a thin white layer of sleet. We kept slipping and falling. I could hear Grandpa mumbling and grumbling. The wind-driven sleet stung our skin like thousands of pricking needles. Strong gusts of wind growled and moaned through the tops of the tall timber.

Once during a momentary lull of the storm, I thought I heard the baying of a hound. I told my father I thought I had heard Old Dan.

"From which direction?" he asked.

"From that way," I said, pointing to our left.

We started on. A few minutes later Papa stopped. He shouted to my grandfather, "Did you hear anything?"

"No," Grandpa shouted back. "I can't hear anything in this storm."

"I thought I did, but I'm not sure," the judge said.

"Where was it coming from?" Papa asked.

"Over that way," the judge said, pointing to our right.

"That's the way it sounded to me," Papa said.

At that moment, all of us heard the deep voice of Old Dan.

"It sounds as if they're close," Grandpa said.

"Let's split up," said the judge. "Maybe one of us can find them."

"No," Papa said, "it'd be easy to get lost in this storm."

"I think they're more to the right of us," I said.

"I do, too," Papa said.

We trudged on. Old Dan bawled again. The sound of his voice seemed to be all around us.

"The way that wind is whipping the sound through this timber," the judge said, "we'd be lucky if we ever found them."

Papa shouted over the roar of the wind, "We can't take much more of this. We'll freeze to death."

The men were giving up. I felt the knot again as it crawled up in my throat. Salt water froze on my eyelashes. Kneeling down, I put my ear close to the icy ground in hopes I could hear my dogs, but I couldn't hear anything above the roar of the blizzard.

Standing up, I peered this way and that. All I could see was a white wall of whirling sleet. I closed my eyes and said a silent prayer and hoped for a miracle.

We heard a sharp crack and a loud crashing noise. A large limb, torn from a tree by the strong wind, fell to the ground. The sharp crack of the limb gave me the idea. Shouting to my father, I said, "Shoot the gun. If my dogs are close enough to hear it, maybe Little Ann will come to us."

Papa didn't hesitate. Pointing the gun high over his head, he pulled the trigger. The sharp crack rang out into the teeth of the storm.

We waited.

Just when I had given up all hope and had sunk to the lowest depth of despair, out of the white wall of driving sleet, my little dog came to me. I knelt down and gathered her in my arms.

Taking one of the lead ropes from my pocket, I tied it to her collar. I said, "Find him, little girl. Please find Old Dan."

Right then I didn't care about coons, gold cups, or anything. All I wanted was my dogs.

I don't know how she did it. Straight into the face of the storm she led us. Time after time she would stop and turn



her head this way and that. I knew she couldn't scent or see anything. Instinct alone was guiding her. Over a winding and twisting trail, we followed.

Coming out of the bottoms, she led us into a thick canebrake. The tall stalks sheltered us from the storm. The roaring of the wind didn't seem as loud. Like ghostly figures, large trees loomed out of the almost solid mass. Falling and stumbling, we kept pushing on.

Grandpa shouted, "Hold up a minute. I'm just about all in."  
We stopped.

"Do you think that hound knows what she's doing?" the judge asked. "Maybe we're just running around in circles."

Looking at me, Papa said, "I hope she does. Some of these canebrakes cover miles. If we get lost in here, we'll be in bad shape."

Grandpa said, "I think we've gone too far. The last time I heard Old Dan, he sounded quite close."

"That was because the wind carried the sound," I said.

The judge spoke up, "Fellows, no dog is worth the lives of three men. Now let's do the smart thing and get out of here while we can. Our clothes are wet. If we keep on wandering around in this jungle, we'll freeze to death. It doesn't look like this blizzard is ever going to let up."

I could hear the roar of the blizzard back in the thick timber of the bottoms. Two large limbs being rubbed together by the strong wind made a grinding creaking sound. The tall slender cane around us rattled and swayed.

I could feel the silence closing in. I knew the judge's cold logic had had its effect on my father and grandfather. The men had given up. There was no hope left for me.

Kneeling down, I put my arms around Little Ann. I felt the warm heat from her moist tongue caressing my ear. Closing my eyes, I said, "Please, Dan, bawl one more time, just one more time."

I waited for my plea to be answered.

With its loud roaring, the north wind seemed to be laughing at us. All around, tall stalks of cane were weaving and dancing to the rattling rhythm of their knife-edged blades.

My father tried to talk above the wind, but his words were lost in the storm. Just before another blast, clear as a fog-horn on a stormy sea, Old Dan's voice rang loud and clear. It seemed louder than the roar of the wind or the skeleton-like rustling of the tall swaying cane.

I jumped to my feet. My heart did a complete flip-flop. The knot in my throat felt as big as an apple. I tried to whoop, but it was no use. Little Ann bawled and tugged on the rope.

There was no mistaking the direction. We knew that Little Ann had been right all along. Straight as an arrow, she had led us to him.

Old Dan was treed down in a deep gully. I slid off the bank and ran to him. His back was covered with a layer of frozen sleet. His frost-covered whiskers stood out straight as porcupine quills.

I worked the wedges of ice from between his toes, and scraped the sleet from his body with my hands. Little Ann came over and tried to wash his face. He didn't like it. Jerking loose from me, he ran over to the tree, reared up on it, and started bawling.

Hearing shouting from the bank above me, I looked up. I could dimly see Papa and the judge through the driving sleet.

At first I thought they were shouting to me, but on peering closer I could see that they had their backs to me. Catching hold of some long stalks of cane that were hanging down from the steep bank, I pulled myself up.

Papa shouted in my ear, "Something has happened to your grandfather."

Turning to the judge, he said, "He was behind you. When was the last time you saw him?"

"I don't know for sure," the judge said. "I guess it was back there when we heard the hound bawl."

"Didn't you hear anything?" Papa asked.

"Hear anything?" the judge exclaimed. "How could I hear anything in all that noise? I thought he was behind me all the time, and didn't miss him until we got here."

I couldn't hold back the tears. My grandfather was lost and wandering in that white jungle of cane. Screaming for him, I started back.

Papa caught me. He shouted, "Don't do that."

I tried to tear away from him but his grip on my arm was firm.

"Shoot the gun," the judge said.

Papa shot time after time. It was useless. We got no answer.

Little Ann came up out of the washout. She stood and stared at me. Turning, she disappeared quickly in the thick cane. Minutes later we heard her. It was a long, mournful cry.

The only times I had ever heard my little dog bawl like that were when she was baying at a bright Ozark moon, or when someone played a French harp or a fiddle close to her ear. She didn't stop until we reached her.

Grandpa lay as he had fallen, face down in the icy sleet. His

right foot was wedged in the fork of a broken box elder limb. When the ankle had twisted, the searing pain must have made him unconscious.

Papa worked Grandpa's foot free and turned him over. I sat down and placed his head in my lap. While Papa and the judge massaged his arms and legs, I wiped the frozen sleet from his eyes and face.

Burying my face in the iron-gray hair, I cried and begged God not to let my grandfather die.

"I think he's gone," the judge said.

"I don't think so," Papa said. "He took a bad fall when that limb tripped him, but he hasn't been lying here long enough to be frozen. I think he's just unconscious."

Papa lifted him to a sitting position and told the judge to start slapping his face. Grandpa moaned and moved his head.

"He's coming around," Papa said.

I asked Papa if we could get him back to the gully where Old Dan was. I had noticed there was very little wind there and we could build a fire.

"That's the very place," he said. "We'll build a good fire and one of us can go for help."

Papa and the judge made a seat by catching each other's wrists. They eased Grandpa between them.

By the time we reached the washout, Grandpa was fully conscious again, and was mumbling and grumbling. He couldn't see why they had to carry him like a baby.

After easing him over the bank and down into the gully, we built a large fire. Papa took his knife and cut the boot from Grandpa's swollen foot. Grandpa grunted and groaned from



the pain. I felt sorry for him but there was nothing I could do but look on.

Papa examined the foot. Shaking his head, he said, "Boy, that's a bad one. It's either broken or badly sprained. I'll go for some help."

Grandpa said, "Now wait just a minute. I'm not going to let you go out in that blizzard by yourself. What if something happens to you? No one would know."

"What time is it?" he asked.

The judge looked at his watch. "It's almost five o'clock," he said.

"It's not long till daylight," Grandpa said. "Then if you want to go, you can see where you're going. Now help me get propped up against this bank. I'll be all right. It doesn't hurt any more. It's numb now."

"He's right," the judge said.

"Think you can stand it?" Papa asked.

Grandpa roared like a bear. "Sure I can stand it. It's nothing but a sprained ankle. I'm not going to die. Build that fire up a little more."

While Papa and the judge made Grandpa comfortable, I carried wood for the fire.

"There's no use standing around gawking at me," Grandpa said. "I'm all right. Get the coon out of that tree. That's what we came for, isn't it?"

Up until then, the coon-hunting had practically been forgotten.

The tree was about thirty feet from our fire. We walked over and took a good look at it for the first time. My dogs,

seeing we were finally going to pay some attention to them, started bawling and running around the tree.

Papa said, "It's not much of a tree, just an old box elder snag. There's not a limb on it."

"I can't see any coon," said the judge. "It must be hollow."

Papa beat on its side with the ax. It gave forth a loud booming sound. He said, "It's hollow all right."

He stepped back a few steps, scraped his feet on the slick ground for a good footing, and said, "Stand back, and hold those hounds. I'm going to cut it down. We need some wood for our fire anyway."

Squatting down between my dogs, I held onto their collars.

Papa notched the old snag so it would fall away from our fire. As the heavy ax chewed its way into the tree, it began to lean and crack. Papa stopped chopping. He said to the judge, "Come on and help me. I think we can push it over now."

After much grunting and pushing, snapping and popping, it fell.

I turned my dogs loose.

On hitting the ground, the snag split and broke up. Goggle-eyed, I stood rooted in my tracks and watched three big coons roll out of the busted old trunk.

One started up the washout, running between us and the fire. Old Dan caught him and the fight was on. The second coon headed down the washout. Little Ann caught him.

Hearing a loud yell from Grandpa, I looked that way. Old Dan and the coon were fighting close to his feet. He was yelling and beating at them with his hat. The judge and Papa ran to help.

The third coon started climbing up the steep bank close to me. Just before reaching the top, his claws slipped in the icy mud. Tumbling end over end, down he came. I grabbed up a stick and threw it at him. Growling and showing his teeth, he started for me. I threw the fight to him then and there. Some ten yards away I looked back. He was climbing the bank. That time he made it and disappeared in the thick cane.

Hearing a squall of pain from Little Ann, I turned. The coon was really working her over. He had climbed up on her back and was tearing and slashing. She couldn't shake him off. Grabbing a club from the ground, I ran to help her.

Before we had killed our coon, Old Dan came tearing in. We stood and watched the fight. When the coon was dead, Papa picked it up and we walked back to the fire.

"How many coons were in that old snag?" Papa asked.

"I saw three," I said. "The one that got away climbed out over there." I pointed in the direction the coon had taken.

I never should have pointed. My dogs turned as one, and started bawling and clawing their way up the steep bank. I shouted and scolded, but to no avail. They disappeared in the rattling cane.

We stood still, listening to their voices. The sound died away in the roaring storm. Sitting down close to the fire, I buried my face in my arms and cried.

I heard the judge say to my father, "This beats anything I have ever seen. Why, those dogs can read that boy's mind. He just pointed at that bank and away they went. I never saw anything like it. I can't understand some of the things they have done tonight. Hounds usually aren't that smart. If they were

collies, or some other breed of dog, it would be different, but they're just redbone hounds, hunting dogs."

Papa said, "Yes, I know what you mean. I've seen them do things that I couldn't understand. I'd never heard of hounds that ever had any affection for anyone, but these dogs are different. Did you know they won't hunt with anyone but him, not even me?"

Hearing my grandfather call my name, I went over and sat down by his side. Putting his arm around me, he said, "Now, I wouldn't worry about those dogs. They'll be all right. It's not long till daylight. Then you can go to them."

I said, "Yes, but what if the coon crosses the river? My dogs will follow him. If they get wet they could freeze to death."

"We'll just have to wait and hope for the best," he said. "Now straighten up and quit that sniffing. Act like a coon hunter. You don't see me bawling, and this old foot is paining me something awful."

I felt better after my talk with Grandpa.

"Come on, let's skin these coons," Papa said.

I got up to help him.

After the skins were peeled from the carcasses, I had an idea. Holding one up close to the fire until it was warm, I took it over and wrapped it around Grandpa's foot. Chuckling, he said, "Boy, that feels good. Heat another skin the same way."

I kept it up for the rest of the night.

## *EIGHTEEN*

**J**UST BEFORE DAWN, THE STORM blew itself out with one last angry roar. It started snowing. A frozen silence settled over the canebrake.

Back in the thick timber of the river bottoms, the sharp snapping of frozen limbs could be heard. The tall stalks of wild cane looked exhausted from the hellish night. They were drooping and bending from the weight of the frozen sleet.

I climbed out of the deep gully and listened for my dogs. I couldn't hear them. Just as I started back down the bank, I heard something. I listened. Again I heard the sound.

Papa was watching me. "Can you hear the dogs?" he asked.

"No, not the dogs," I said, "but I can hear something else."

"What does it sound like?" he asked.

"Like someone whooping," I said.

Papa and the judge hurried up the bank. We heard the sound again. It was coming from a different direction.



"The first time I heard it," I said, "it was over that way."

"It's the men from camp," the judge said. "They're searching for us."

We started whooping. The searchers answered. Their voices came from all directions. The first one to reach us was Mr. Kyle. He looked haggard and tired. He asked if everything was all right.

"Yes, we're all right," Papa said, "but the old man has a bad ankle. It looks like we'll have to carry him out."

"Your team broke loose and came back to camp about midnight," Mr. Kyle said. "This really spooked us. We were sure something bad had happened. Twenty-five of us have been searching since then."

Several men climbed down the bank and went over to Grandpa. They looked at his ankle. One said, "I don't think it's broken, but it sure is a bad sprain."

"You're in luck," another one said. "We have one of the best doctors in the state of Texas in our camp, Dr. Charley Lathman. He'll have you fixed up in no time."

"Yes," another said, "and if I know Charley, he's probably got a small hospital with him."

Back in the crowd, I heard another man say, "You mean that Lathman fellow, who owns those black and tan hounds, is a doctor?"

"Sure is," another said. "One of the best."

Mr. Kyle asked where my dogs were. I told him that they were treed somewhere.

"What do you mean, treed somewhere?" he asked.

Papa explained what had happened.

With a wide-eyed look on his face, he said, "Do you mean to tell me those hounds stayed with the tree in that blizzard?"

I nodded.

Looking at me, he said, "Son, I hope they have that coon treed, because you need that one to win the cup. Those two walker hounds caught three before the storm came up. When it got bad, all the hunters came in."

The judge spoke up. "I'll always believe that those hounds knew that boy needed another coon to win," he said. "If you fellows had seen some of the things those dogs have done, you'd believe it, too."

One hunter walked over to the broken snag. "Three out of one tree," he said. "No wonder, look here! That old snag was half-full of leaves and grass. Why, it was a regular old den tree."

Several of the men walked over. I heard one say, "I've seen this happen before. Remember that big hunt in the Red River bottoms, when the two little beagle hounds treed four coons in an old hollow snag? They won the championship, too."

"I wasn't there but I remember reading about it," one said.

"Say, I don't see Benson," Mr. Kyle said.

The men started looking at each other.

"He was searching farther downriver than the rest of us," one fellow said. "Maybe he didn't hear us shouting."

Some of the men climbed out of the gully. They started whooping. From a distance we heard an answering shout.

"He hears us," someone said. "He's coming."

Everyone looked relieved.

Mr. Benson struck the washout a little way above us. He

was breathing hard, as if he'd been running. He started talking as soon as he was within hearing distance.

"It scared me when I first saw them," he said. "I didn't know what they were. They looked like white ghosts. I'd never seen anything like it."

A hunter grabbed Mr. Benson by the shoulder, shaking him. "Get ahold of yourself, man," he said. "What are you talking about?"

Mr. Benson took a deep breath to control himself, and started again in a much calmer voice. "Those two hounds," he said. "I found them. They're frozen solid. They're nothing but white ice from the tips of their noses to the ends of their tails."

Hearing Mr. Benson's words, I screamed and ran to my father. Everything started whirling around and around. I felt light as a feather. My knees buckled. I knew no more.

Regaining consciousness, I opened my eyes and could dimly see the blurry images of the men around me. A hand was shaking me. I could hear my father's voice but I couldn't understand his words. Little by little the blackness faded away. My throat was dry and I was terribly thirsty. I asked for some water.

Mr. Benson came over. He said, "Son, I'm sorry, truly sorry. I didn't mean it that way. Your dogs are alive. I guess I was excited. I'm very sorry."

I heard a deep voice say, "That's a hell of a thing to do. Come running in here saying the dogs are frozen solid."

Mr. Benson said, "I didn't mean it to sound that way. I said I'm sorry. What more do you want me to do?"

The deep voice growled again. "I still think it was a hell of a thing for a man to do."



Mr. Kyle took over. "Now let's not have any more of this," he said. "We have work to do. We've been standing here acting like a bunch of schoolkids. All this time that old man has been lying there suffering. A couple of you men cut two poles and make a stretcher to carry him."

While the men were getting the poles, Papa heated the coonskins again and rewrapped Grandpa's foot.

With belts and long leather laces from their boots, the hunters made a stretcher. Very gently they put Grandpa on it.

Again Mr. Kyle took command. "Part of us will start for camp with him," he said. "The others will go after the dogs."

"Here, take this gun," Papa said. "I'll go with him."

Looking at me, Mr. Kyle said, "Come on, son. I want to see your hounds."

Mr. Benson led the way. "As soon as we get out of this cane," he said, "we may be able to hear them. They have the coon treed in a big black gum tree. You're going to see a sight. Now I mean a sight. They've walked a ring around that tree clear down through the ice and snow. You can see the bare ground."

"Wonder why they did that?" someone asked.

"I don't know," Mr. Benson replied, "unless they ran in that circle to keep from freezing to death, or to keep the coon in the tree."

I figured I knew why my dogs were covered with ice. The coon had probably crossed the river, maybe several times. Old Dan and Little Ann would have followed him. They had come out of the river with their coats dripping wet, and the freezing blast of the blizzard had done the rest.

Nearing the tree, we stopped and stared.

"Did you ever see anything like that?" Mr. Benson asked. "When I first saw them, I thought they were white wolves."

My dogs hadn't seen us when we came up. They were trotting round and round. Just as Mr. Benson had said, we could see the path they had worn down through the ice and snow till the bare black earth was visible. Like ghostly white shadows, around and around they trotted.

In a low voice, someone said, "They know that if they stop they'll freeze to death."

"It's unbelievable," said Mr. Kyle. "Come on. We must do something quick."

With a choking sob, I ran for my dogs.

On hearing our approach, they sat down and started bawling treed. I noticed their voices didn't have that solid ring. Their ice-covered tails made a rattling sound as they switched this way and that on the icy ground.

A large fire was built. Standing my dogs close to the warm heat, the gentle hands of the hunters went to work. With handkerchiefs and scarves heated steaming hot, little by little the ice was thawed from their bodies.

"If they had ever lain down," someone said, "they would've frozen to death."

"They knew it," another said. "That's why they kept running in that circle."

"What I can't understand is why they stayed with the tree," Mr. Benson said. "I've seen hounds stay with a tree for a while, but not in a northern blizzard."

"Men," said Mr. Kyle, "people have been trying to understand dogs ever since the beginning of time. One never knows

what they'll do. You can read every day where a dog saved the life of a drowning child, or lay down his life for his master. Some people call this loyalty. I don't. I may be wrong, but I call it love—the deepest kind of love.”

After these words were spoken, a thoughtful silence settled over the men. The mood was broken by the deep growling voice I had heard back in the washout.

“It's a shame that people all over the world can't have that kind of love in their hearts,” he said. “There would be no wars, slaughter, or murder; no greed or selfishness. It would be the kind of world that God wants us to have—a wonderful world.”

After all the ice was thawed from my dogs and their coats were dried out, I could see they were all right. I was happy again and felt good all over.

One of the hunters said, “Do you think those hounds are thawed out enough to fight a coon?”

“Sure, just run him out of that tree,” I said.

At the crack of the gun, the coon ran far out on a big limb and stopped. Again the hunter sprinkled him with bird shot. This time he jumped. Hitting the ground, he crouched down.

Old Dan made a lunge. Just as he reached him, the coon sprang straight up and came down on his head. Holding on with his claws, the coon sank his teeth in a long tender ear. Old Dan was furious. He started turning in a circle, bawling with pain.

Little Ann was trying hard to get ahold of the coon but she couldn't. Because of his fast circling, Old Dan's feet flew out from under him and he fell. This gave Little Ann a chance.

Darting in, her jaws closed on the back of the coon's neck. I knew the fight was over.

Arriving back at camp, I saw that all the tents had been taken down but ours. A hunter said, "Everyone was in a hurry to get out before another blizzard sets in."

Papa told me to take my dogs into the tent as Grandpa wanted to see them.

I saw tears in my grandfather's eyes as he talked to them. His ankle was wrapped in bandages. His foot and toes were swollen to twice their normal size. They had turned a greenish-yellow color. Placing my hand on his foot, I could feel the feverish heat.

Dr. Lathman came over. "Are you ready to go now?" he asked.

Snorting and growling, Grandpa said, "I told you I wasn't going anywhere till I see the gold cup handed to this boy."

Turning to face the crowd, Dr. Lathman said, "Men, let's get this over. I want to get this man to town. That's one of the meanest sprains I've ever seen and it should be in a cast, but I don't have any plaster of Paris with me."

The hunter who had come by our tent collecting the jackpot money came up to me. Handing me the box, he said, "Here you are, son. There's over three hundred dollars in this box. It's all yours."

Turning to the crowd, he said, "Fellows, I can always say this. On this hunt I've seen two of the finest little coon hounds I ever hope to see."

There was a roar of approval from the crowd.

Looking down, I saw the box was almost full of money. I was shaking all over. I tried to say "Thanks," but it was only a



whisper. Turning, I handed the box to my father. As his rough old hands closed around it, I saw a strange look come over his face. He turned and looked at my dogs.

Some of the men started shouting, "Here it is!"

The crowd parted and the judge walked through. I saw the gleaming metal of the gold cup in his hand. After a short speech, he handed it to me, saying, "Son, this makes me very proud. It's a great honor to present you with this championship cup."

The crowd exploded. The hunters' shouts were deafening.

I don't know from where the two silly old tears came. They just squeezed their way out. I felt them as they rolled down my cheeks. One dropped on the smooth surface of the cup and splattered. I wiped it away with my sleeve.

Turning to my dogs, I knelt down and showed the cup to them. Little Ann licked it. Old Dan sniffed one time, and then turned his head away.

The judge said, "Son, there's a place on the cup to engrave the names of your dogs. I can take it into Oklahoma City and have it done, or you can have it done yourself. The engraving charge has already been paid by the association."

Looking at the cup, it seemed that far down in the gleaming shadows I could see two wide blue eyes glued to a window-pane. I knew that my little sister was watching the road and waiting for our return. Looking back at the judge, I said, "If you don't mind, I'll take it with me. My grandfather can send it in for me."

Laughing, he said, "That's all right." Handing me a slip of paper, he said, "This is the address where you should send it."

Grandpa said, "Now that that's settled, I'm ready to go

to town." Turning to Papa, he said, "You'll have to bring the buggy, and I wish you'd look after my stock. I know Grandma will want to go in with us and there'll be no one there to feed them. Tell Bill Lowery to come up and take care of the store. You'll find the keys in the usual place."

"Well take care of everything," Papa said. "Don't worry about a thing. I don't intend to stop until we get back, because it looks like we're in for some more bad weather."

I went over and kissed Grandpa good-bye. He pinched my cheek, and whispered, "We'll teach these city slickers that they can't come up here and beat our dogs."

I smiled.

Grandpa was carried out and made comfortable in the back seat of Dr. Lathman's car. I stood and watched as it wheezed and bounced its way out of sight.

"While I'm harnessing the team," Papa said, "you take the tent down and pack our gear."

On the back seat of the buggy, I made a bed out of our bed-clothes. Down on the floor boards, I fixed a nice place for my dogs.

All through the night, the creaking wheels of our buggy moved on. Several times I woke up. My father had wrapped a tarp around himself. Reaching down, I could feel my dogs. They were warm and comfortable.

Early the next morning, we stopped for breakfast. While Papa tended to the team, I turned my dogs loose and let them stretch.

"We made good time last night," Papa said. "If everything goes right, we'll be home long before dark."

Reaching Grandpa's store in the middle of the afternoon, Papa said, "I'll put the team in the barn and feed the stock while you unload the buggy."

Coming back from the barn, he said, "In the morning, I'll go over and tell Bill Lowery to come up and open the store."

Looking around, he said, "It snowed more here than it did where we were hunting."

Feeling big and important, I said, "I don't like the looks of this weather. We'd better be scooting for home."

Papa laughed. "Sure you're not in a hurry to get home to show off the gold cup?" he asked.

A smile was my only answer.

Two hundred yards this side of our home, the road made a turn around a low foothill shutting our house off from view.

Papa said, "You're going to see a scramble as soon as we round that bend."

It was more of a stampede than a scramble. The little one came out first, and all but tore the screen door from its hinges. The older girls passed her just beyond the gate. In her hurry, she slipped and fell face down in the snow. She started crying.

The older girls ran up asking for the cup.

Holding it high over my head, I said, "Now wait a minute. I've got another one for you two." I held the small silver cup out to them.

While they were fighting over it, I ran to the little one. Picking her up, I brushed the snow from her long, braided hair and her tear-stained face. I told her there was no use to cry. I had brought the gold cup to her, and no one else was going to get it.

Reaching for the cup, she wrapped her small arms around it. Squeezing it up tight, she ran for the house to show it to Mama.

Mama came out on the porch. She was just as excited as the girls were. She held out her arms. I ran to her. She hugged me and kissed me.

"It's good to have you home again," she said.

"Look what I have, Mama," the little one cried, "and it's all mine."

She held the golden cup out in her two small hands.

As Mama took the beautiful cup, she looked at me. She started to say something but was interrupted by the cries from the other girls.

"We have one, too, Mama," they cried, "and it's just as pretty as that one."

"It's not either," the little one piped in a defiant voice. "It's not even as big as mine."

"Two cups!" Mama exclaimed. "Did you win two?"

"Yes, Mama," I said. "Little Ann won that one all by herself."

The awed expression on my mother's face was wonderful to see. Holding a cup in each hand, she held them out in front of her.

"Two," she said. "A gold one and a silver one. Who would have thought anything so wonderful could have happened to us. I'm so proud; so very proud."

Handing the cups back to the girls, she walked over to Papa. After kissing him, she said, "I just can't believe everything that has happened. I'm so glad you went along. Did you enjoy yourself?"



With a smile on his face, Papa almost shouted, "Enjoy myself? Why, I never had such a time in my life."

His voice trailed off to a low calm, "That is, except for one thing. Grandpa had a bad accident."

"Yes, I know," Mama said. "One of Tom Logan's boys was at the store when they arrived. He came by and told us all about it. The doctor said it wasn't as bad as it looked, and he was pretty sure Grandpa would be home in a few days."

I was happy to hear this news, and could tell by the pleased look on my father's face, he was glad to hear it, too.

On entering the house, Papa said, "Oh, I almost forgot." He handed the box of money to Mama.

"What's this?" she asked.

"Oh, it's just a little gift from Old Dan and Little Ann," Papa said.

Mama opened the box. I saw the color drain from her face. Her hands started trembling. Turning her back to us, she walked over and set it on the mantel. A peaceful silence settled over the room. I could hear the clock ticking away. The fire in the fireplace crackled and popped.

Turning from the mantel, Mama looked straight at us. Her lips were tightly pressed together to keep them from quivering. Walking slowly to Papa, she buried her face in his chest. I heard her say, "Thank God, my prayers have been answered."

There was a celebration in our home that night. To me it was like a second Christmas.

Mama opened a jar of huckleberries and made a large cobbler. Papa went to the smokehouse and came back with a hickory-cured ham. We sat down to a feast of the ham, huge

plates of fried potatoes, ham gravy, hot corn bread, fresh butter, and wild bee honey.

During the course of the meal, the entire story of the championship hunt was told, some by Papa but mostly by me.

Just when everything was so perfect and peaceful, an argument sprang up between the two oldest girls. It seemed that each wanted to claim the silver cup. Just when they were on the verge of sawing it in two, so each would have her allotted share, Papa settled the squabble by giving the oldest one a silver dollar. Once again peace and harmony was restored.

That night as I was preparing for bed, a light flashed by my window. Puzzled, I tiptoed over and peeked through the pane. It was Mama. Carrying my lantern and two large plates heaped high with food, she was heading for the doghouse. Setting the light down on the ground in front of it, she called to my dogs. While they were eating, Mama did something I couldn't understand. She knelt down on her knees in prayer.

After they had eaten their food, Mama started petting them. I could hear her voice but couldn't make out her words. Whatever she was saying must have pleased them. Little Ann wiggled and twisted. Even Old Dan wagged his long red tail, which was very unusual.

Papa came out. I saw him put his arm around Mama. Side by side they stood for several minutes looking at my dogs. When they turned to enter the house, I saw Mama dab at her eyes with her apron.

Lying in bed, staring into the darkness, I tried hard to figure out the strange actions of my parents. Why had Mama knelt in prayer in front of my dogs? Why had she wept?

I was running all the why's around in my mind when I heard them talking.

"I know," Papa said, "but I think there's a way. I'm going to have a talk with Grandpa. I don't think that old foot of his is ever going to be the same again. He's going to need some help around the store."

I knew they were talking about me, but I couldn't understand what they meant. Then I thought, "Why, that's it. They want me to help Grandpa." That would be all right with me. I could still hunt every night.

Feeling smart for figuring out their conversation, I turned over and fell asleep.

## NINETEEN

**A**LTHOUGH THE WINNING OF THE cups and the money was a big event in my life, it didn't change my hunting any. I was out after the ringtails every night.

I had been hunting the river bottoms hard for about three weeks. On that night, I decided to go back to the Cyclone Timber country. I had barely reached the hunting ground when my dogs struck a trail. Old Dan opened up first.

They struck the trail on a ridge and then dropped down into a deep canyon, up the other side, and broke out into some flats. I could tell that the scent was hot from their steady bawling. Three times they treed the animal.

Every time I came close to the tree, the animal would jump, and the race would be on. After a while, I knew it wasn't a coon. I decided it was a bobcat.

I didn't like to have my dogs tree the big cats, for their

fur wasn't any good, and all I could expect was two cut-up hounds.

They could kill the largest bobcat in the hills, and had on several occasions, but to me it was useless. The only good I could see in killing one was getting rid of a vicious predatory animal.

The fourth time they treed, they were on top of a mountain. After the long chase, I figured the animal was winded and would stay in the tree. In a trot I started to them.

As I neared the tree, Little Ann came to me, reared up, and whined. By her actions, I knew something was wrong. I stopped. In the moonlight, I could see Old Dan sitting on his haunches, staring up at the tree and bawling.

The tree had lots of dead leaves on it. I knew it was a large white oak because it is one of the last trees in the mountains to lose its leaves.

Old Dan kept bawling. Then he did something he had never done before. For seconds his deep voice was still, and silence settled over the mountains. My eyes wandered from the tree to him. His lips were curled back and he snarled as he stared into the dark foliage of the tree. His teeth gleamed white in the moonlight. The hair on his neck and along his back stood on end. A low, deep, rumbling growl rolled from his throat.

I was scared and I called to him. I wanted to get away from there. Again I called, but it was no use. He wouldn't leave the tree, for in his veins flowed the breded blood of a hunting hound. In his fighting heart, there was no fear.

I set the lantern down and tightened my grip on the handle



of the ax. Slowly I started walking toward him. I thought, "If I can get close enough to him, I can grab his collar." I kept my eyes on the tree as I edged forward. Little Ann stayed by my side. She, too, was watching the tree.

Then I saw them—two burning, yellow eyes—staring at me from the shadowy foliage of the tree. I stopped, petrified with fear.

The deep baying of Old Dan stopped and again the silence closed in.

I stared back at the unblinking eyes.

I could make out the bulk of a large animal, crouched on a huge branch, close to the trunk of the big tree. Then it moved. I heard the scratch of razor-sharp claws on the bark. It stood up and moved out of the shadows on to the limb. I saw it clearly as it passed between the moon and me. I knew what it was. It was the devil cat of the Ozarks, the mountain lion.

The silence was shattered by one long, loud bawl from Old Dan. I'd never heard my dog bawl like that. It was different. His voice rang out over the mountains, loud and clear. The vibration of the deep tones rolled in the silence of the frosty night, on and on, out over the flats, down in the canyons, and died away in the rimrocks, like the cry of a lost soul. Old Dan had voiced his challenge to the devil cat.

There was a low cough and a deep growl from the lion. I saw him crouch. I knew what was coming. My hands felt hot and sweaty on the smooth ash handle of the ax. With a blood-curdling scream he sprang from the tree with claws outspread and long, yellow fangs bared.

Old Dan didn't wait. Rearing up on his hind legs, he met

the lion in the air. The heavy weight bowled him over and over. He wound up in a fallen treetop.

The impact of the two bodies threw the lion off balance. Little Ann darted in. Her aim was true. I heard the snap of her steel-trap jaws as they closed on his throat.

With a squall of pain and rage, the big cat rolled over on his side, dragging Little Ann with him. His right paw reached out and curved over her shoulder. Sinews tightened and razor-sharp claws dug inward. With a cry of pain, she loosened her hold. I saw the blood squirting from the deep wound in her shoulder. She ignored it and bored back into the fight.

Old Dan, stunned for an instant from the impact of the lion's body, fought his way from the treetop. Bawling the cry of the damned, he charged back in.

I went berserk, and charged into the fight.

There in the flinty hills of the Ozarks, I fought for the lives of my dogs. I fought with the only weapon I had, the sharp cutting blade of a double-bitted ax.

Screaming like a madman, with tears running down my face, I hacked and chopped at the big snarling mountain cat.

Once, feeling the bite of the sharp blade, the devil cat turned on me. His yellow slitted eyes burned with hate. The long, lithe body dipped low to the ground. The shoulder muscles knotted and bulged. I tried to jump back but my foot slipped and I dropped to my knees. I knew I was trapped. With a terrifying scream he sprang.

I never saw my dogs when they got between the lion and me, but they were there. Side by side, they rose up from the ground as one. They sailed straight into those jaws of death,

their small, red bodies taking the ripping, slashing claws meant for me.

I screamed and charged back into the fight, swinging my ax, but I was careful not to hit one of my dogs.

The battle raged on and on, down the side of the mountain, over huckleberry bushes, fallen logs, and rocks. It was a rolling, tumbling mass of fighting fury. I was in the middle of it all, falling, screaming, crying and hacking away at every opportunity.

I had cut the big cat several times. Blood showed red on the bit of the ax, but as yet I had not gotten in the fatal lick. I knew it had to be soon for my dogs were no match against the razor-sharp claws and the long, yellow fangs.

The screams of the big cat and the deep bellowing voices of my dogs echoed through the mountains as if the demons of hell had been turned loose. Down the side of the mountain, the terrible fight went on, down to the very bottom of the canyon.

The big cat had Old Dan by the throat. I knew he was seeking to cut the all-important vein, the jugular. At the pitiful bawl of Old Dan, Little Ann, throwing caution to the wind, ran in and sank her teeth in the lion's tough neck.

With her claws digging into the mountain soil, she braced herself, and started pulling. The muscles in her small legs knotted and quivered. She was trying hard to pull the devil cat's fangs from the throat of Old Dan.

In the rays of a bright Ozark moon, I could see clearly. For an instant I saw the broad back of the big cat. I saw the knotty bulge of steel-bound muscle, the piston-like jerk of the deadly



hind claws, trying for the downward stroke that could disembowel a dog.

Raising the ax high over my head, I brought it down with all the strength in my body. My aim was true. Behind the shoulders, in the broad muscular back, the heavy blade sank with a sickening sound. The keen edge cleaved through the tough skin. It seemed to hiss as it sliced its way through bone and gristle.

I left the ax where it was, sunk to the eye in the back of the devil cat.

He loosened his hold on the throat of Old Dan. With a scream of pain, he reared up on his hind legs and started pawing the air. Little Ann dangled from his neck, still holding on. Her eyes were shut tight and her small feet were digging and clawing at the body.

Old Dan, spewing blood from a dozen wounds, leaped high in the air. His long, red body sailed in between the outspread paws of the lion. I heard the snap of his powerful jaws as they closed on the throat.

The big cat screamed again. Blood gurgled and sprayed. In a bright red mist, it rained out over the underbrush and rattled like sleet on the white oak leaves. In a boxer's stance, he stood and clawed the air. His slitted eyes turned green with hate. He seemed to be unaware of the two hounds hanging from his body, and kept staring at me. I stood in a trance and stared back at the ghastly scene.

The breath of life was slowly leaving him. He was dying on his feet but refusing to go down. My ax handle stuck straight out from his back. Blood, gushing from the mortal wound,

glistened in the moonlight. A shudder ran through his body. He tried once again to scream. Blood gurgled in his throat.

It was the end of the trail for the scourge of the mountains. No more would he scream his challenge from the rimrocks to the valley below. The small, harmless calves and the young colts would be safe from his silent stalk.

He fell toward me. It seemed that with his last effort he was still trying to get at me.

As his heavy body struck the ground, something exploded in my head. I knew no more.

When I came to, I was sitting down. It was silent and still. A bird, disturbed by the fight, started chirping far up on the side of the mountain. A small winter breeze rustled some dead leaves in the deep canyon. A cold, crawling chill crept over my body.

I looked over at the lion. My dogs were still glued to his lifeless body. In his dying convulsions the ax had become dislodged from the wound. It lay there in the moonlight, covered with blood.

My numb brain started working. I thought of another time the ax had been covered with blood. I don't know why I thought of Rubin Pritchard at that time, or why I thought of these words I had often heard: "There is a little good in all evil."

I got to my feet and went over to my dogs. I knew I had to inspect them to see how badly they were hurt. It wasn't too hard to get Little Ann to loosen her hold. I examined her body. She was cut in several places, but nothing fatal. The only bad wound she had was in her shoulder. It was nine inches long

and down to the clean, white bone. She started licking it immediately.

It was different with Old Dan. Try as I might, he wouldn't turn loose. Maybe he could remember the night in the cave when he was a pup. How the big cat had screamed and how he had bawled back at him.

I took hold of his hind legs and tried to pull him loose. It was no use. He knew that the hold he had was a deadly one and he wasn't going to let go. I tried to tell him it was all over, that the lion was dead, to turn loose as I wanted to see how badly he was hurt. He couldn't understand and wouldn't even open his eyes. He was determined to hold on until the body turned cold and stiff.

With my ax handle, I pried apart his locked jaws. Holding onto his collar, I led him off to one side. I couldn't turn him loose as I knew if I did, he would go back to the lion.

With one hand I started examining him. I ran my fingers through the short, red hair. I could feel the quivering muscles and the hot, sweaty skin. He was a bloody mess. His long, velvety ears were shredded. His entire body was a mass of deep, raw, red wounds. On both sides of his rib carriage, the sharp claws had laid the flesh open to the bone.

His friendly old face was pitiful to see. A razor-sharp claw had ripped down on an angle across his right eye. It was swollen shut. I wondered if he would ever see from that eye again.

Blood dripped from his wounds and fell on the white oak leaves. I saw he was bleeding to death. With tears running down my cheeks, I did the only thing a hunter could do. I raked the leaves away and let his blood drip on the black mountain

soil. Mixing it into a mud, I worked it into his wounds to stop the flow of blood.

With my ax in one hand and holding onto his collar with the other, we climbed out of the canyon. I knew if I could get him far enough away from the lion he wouldn't go back.

On reaching the top, I saw the yellow glow of my lantern. I turned Old Dan loose and walked over and picked it up.

Not knowing exactly where I was, I looked down out of the mountains to get my bearings. Beyond the foothills and fields I could see the long, white, crooked line of steam, marking the river's course. Following the snakelike pattern with my eyes, in no time I knew exactly where I was, for I knew every bend in the river.

Anxious to get home so I could take care of my dogs, I turned to call to them. Little Ann was close by. She was sitting down, licking at the wound in her shoulder. I saw the shadowy form of Old Dan sniffing around the tree where the lion had been treed.

As I stood and watched him in the moonlight, my heart swelled with pride. Wounded though he was, he wanted to make sure there were no more lions around.

I called to him. In a stiff-legged trot he came to me. I caught hold of his collar and gave him another inspection. In the lantern light I could see the mud-caked wounds clearly. The bleeding had almost stopped. I felt much better.

Little Ann came over. I knelt down and put my arms around them. I knew that if it hadn't been for their loyalty and unselfish courage I would have probably been killed by the slashing claws of the devil cat.



"I don't know how I'll ever pay you back for what you've done," I said, "but I'll never forget it."

Getting up, I said, "Come on, let's go home so I can take care of those wounds."

I hadn't gone far when I heard a cry. At first I thought it was a bird, or a night hawk. I stood still and listened. I glanced at Little Ann. She was looking behind me. I turned around and looked for Old Dan. He was nowhere in sight.

The cry came again, low and pitiful. Instantly Little Ann started back the way we had come. I followed as fast as I could run.

I found Old Dan lying on his side, pleading for help. What I saw was almost more than I could stand. There, tangled in the low branches of a huckleberry bush, were the entrails of my dog. With a gasping cry I knelt down by his side.

I knew what had happened. Far back in the soft belly, the slashing, razor-sharp claws of the lion had cut into the hollow. In my inspections I had overlooked the wound. His entrails had worked out and had become entangled in the bush. The forward motion of his body had done the rest.

He whimpered as I laid my hand on his head. A warm, red tongue flicked out at it. With tears in my eyes, I started talking to him. "Hang on, boy," I said. "Everything will be all right. I'll take care of you."

With trembling hands, I unwound the entrails from the bush. With my handkerchief I wiped away the gravel, leaves, and pine needles. With fingers that shook, I worked the entrails back into the wound.

Knowing that I couldn't carry him and the ax and lantern, I



stuck the ax deep in the side of a white oak tree. I blew out the lantern and hung the handle over the other blade. I wrapped my dog in my old sheepskin coat and hurried for home.

Arriving home, I awakened my mother and father. Together we doctored my dogs. Old Dan was taken care of first. Very gently Mama worked the entrails out and in a pan of warm soapy water, washed them clean of the pine needles, leaves, and grit.

"If I only knew what I was doing," Mama said, as she worked, "I'd feel better."

With gentle hands, she worked the entrails back through the opening. The wound was sewn up and bandaged with a clean white cloth.

Little Ann wasn't hard to doctor. I held her head while Mama cleaned her wounds with peroxide. Feeling the bite of the strong liquid, she whined and licked at my hands.

"It's all right, little girl," I said. "You'll be well in no time."

I opened the door and watched her as she limped off to the doghouse.

Hearing a whimper, I turned around. There in the doorway to the room stood my sisters. I could tell by the looks on their faces that they had been watching for some time. They looked pitiful standing there in their long white gowns. I felt sorry for them.

"Will Little Ann be all right?" my oldest sister asked.

"Yes," I said, "she'll be all right. She only had one bad wound and we've taken care of that."

"Old Dan's hurt bad, isn't he?" she said.

I nodded my head.

"How bad is it?" she asked.

"It's bad," I said. "He was cut wide open."

They all started crying.

"Now here," Mama said, going over, "you girls get back in bed. You'll take a death of cold being up like this in your bare feet."

"Mommie," the little one said. "God won't let Old Dan die, will He?"

"I don't think so, honey," Mama said. "Now off to bed."

They turned and walked slowly back to their room.

"The way your dogs are cut up," Papa said, "it must have been a terrible fight."

"It was, Papa," I said. "I never saw anything like it. Little Ann wouldn't have fought the lion if it hadn't been for Old Dan. All she was doing was helping him. He wouldn't quit. He just stayed right in there till the end. I even had to pry his jaws loose from the lion's throat after the lion was dead."

Glancing at Old Dan, Papa said, "It's in his blood, Billy. He's a hunting hound, and the best one I ever saw. He only has two loves—you and hunting. That's all he knows."

"If it hadn't been for them, Papa," I said, "I probably wouldn't be here now."

"What do you mean," Mama said, "you wouldn't be here now?"

I told them how the lion had leaped at me and how my dogs had gotten between him and me.

"They were so close together," I said, "when they came up off the ground they looked just like one."

There was a moaning sigh from Mama. She covered her face with her hands and started crying.

"I don't know," she sobbed, "I just don't know. To think

how close you came to being killed. I don't think I can stand any more."

"Now, now," Papa said, as he walked over and put his arms around her. "Don't go all to pieces. It's all over. Let's be thankful and do our best for Old Dan."

"Do you think he'll die, Papa?" I asked.

"I don't know, Billy," Papa said, shaking his head. "He's lost an awful lot of blood and he's a mighty sick dog. All we can do now is wait and see."

Our wait wasn't long. My dog's breathing grew faster and faster, and there was a terrible rattling in his throat. I knelt down and laid his head in my lap.

Old Dan must have known he was dying. Just before he drew one last sigh, and a feeble thump of his tail, his friendly gray eyes closed forever.

At first I couldn't believe my dog was dead. I started talking to him. "Please don't die, Dan," I said. "Don't leave me now."

I looked to Mama for help. Her face was as white as the bark on a sycamore tree and the hurt in her eyes tore at my heart. She opened her mouth to say something but words wouldn't come out.

Feeling as cold as an arctic wind, I got up and stumbled to a chair. Mama came over and said something. Her words were only a murmur in my ears.

Very gently Papa picked Old Dan up in his arms and carried him out on the porch. When he came back in the house, he said, "Well, we did all we could do, but I guess it wasn't enough."

I had never seen my father and mother look so tired and

wearily as they did on that night. I knew they wanted to comfort me, but didn't know what to say.

Papa tried. "Billy," he said, "I wouldn't think too much about this if I were you. It's not good to hurt like that. I believe I'd just try to forget it. Besides, you still have Little Ann."

I wasn't even thinking about Little Ann at that moment. I knew she was all right.

"I'm thankful that I still have her," I said, "but how can I forget Old Dan? He gave his life for me, that's what he did—just laid down his life for me. How can I ever forget something like that?"

Mama said, "It's been a terrible night for all of us. Let's go to bed and try to get some rest. Maybe we'll all feel better tomorrow."

"No, Mama," I said. "You and Papa go on to bed. I think I'll stay up for a while. I couldn't sleep anyway."

Mama started to protest, but Papa shook his head. Arm in arm they walked from the room.

Long after my mother and father had retired, I sat by the fire trying to think and couldn't. I felt numb all over. I knew my dog was dead, but I couldn't believe it. I didn't want to. One day they were both alive and happy. Then that night, just like that, one of them was dead.

I didn't know how long I had been sitting there when I heard a noise out on the porch. I got up, walked over to the door, and listened. It came again, a low whimper and a scratchy sound.

I could think of only one thing that could have made the noise. It had to be my dog. He wasn't dead. He had come back



to life. With a pounding heart, I opened the door and stepped out on the porch.

What I saw was more than I could stand. The noise I had heard had been made by Little Ann. All her life she had slept by Old Dan's side. And although he was dead, she had left the doghouse, had come back to the porch, and snuggled up close to his side.

She looked up at me and whimpered. I couldn't stand it. I didn't know I was running until I tripped and fell. I got to my feet and ran on and on, down through our fields of shocked corn, until I fell face down on the river's bank. There in the gray shadows of a breaking dawn, I cried until I could cry no more.

The churring of gray squirrels in the bright morning sun told me it was daylight. I got to my feet and walked back to the house.

Coming up through our barn lot, I saw my father feeding our stock. He came over and said, "Breakfast is about ready."

"I don't want any breakfast, Papa," I said. "I'm not hungry and I have a job to do. I'll have to bury my dog."

"I tell you what," he said, "I'm not going to be very busy today, so let's have a good breakfast and then I'll help you."

"No, Papa," I said. "I'll take care of it. You go and eat breakfast. Tell Mama I'm not hungry."

I saw a hurt look in my father's eyes. Shaking his head, he turned and walked away.

From rough pine slabs, I made a box for my dog. It was a crude box but it was the best I could do. With strips of burlap and corn shucks, I padded the inside.



Up on the hillside, at the foot of a beautiful red oak tree, I dug his grave. There where the wild mountain flowers would grow in the spring, I laid him away.

I had a purpose in burying my dog up there on the hillside. It was a beautiful spot. From there one could see the country for miles, the long white crooked line of the river, the tall thick timber of the bottoms, the sycamore, birch, and box elder. I thought perhaps that on moonlight nights Old Dan would be able to hear the deep voices of the hounds as they rolled out of the river bottoms on the frosty air.

After the last shovel of dirt was patted in place, I sat down and let my mind drift back through the years. I thought of the old K. C. Baking Powder can, and the first time I saw my pups in the box at the depot. I thought of the fifty dollars, the nickels and dimes, and the fishermen and blackberry patches.

I looked at his grave and, with tears in my eyes, I voiced these words: "You were worth it, old friend, and a thousand times over."

In my heart I knew that there in the grave lay a man's best friend.

Two days later, when I came in from the bottoms where my father and I were clearing land, my mother said, "Billy, you had better look after your dog. She won't eat."

I started looking for her. I went to the barn, the corncrib, and looked under the porch. I called her name. It was no use.

I rounded up my sisters and asked if they had seen Little Ann. The youngest one said she had seen her go down into the garden. I went there, calling her name. She wouldn't answer my call.

I was about to give up, and then I saw her. She had wiggled her way far back under the thorny limbs of a blackberry bush in the corner of the garden. I talked to her and tried to coax her out. She wouldn't budge. I got down on my knees and crawled back to her. As I did, she raised her head and looked at me.

Her eyes told the story. They weren't the soft gray eyes I had looked into so many times. They were dull and cloudy. There was no fire, no life. I couldn't understand.

I carried her back to the house. I offered her food and water. She wouldn't touch it. I noticed how lifeless she was. I thought perhaps she had a wound I had overlooked. I felt and probed with my fingers. I could find nothing.

My father came and looked at her. He shook his head and said, "Billy, it's no use. The life has gone out of her. She has no will to live."

He turned and walked away.

I couldn't believe it. I couldn't.

With eggs and rich cream, I made a liquid. I pried her mouth open and poured it down. She responded to nothing I did. I carried her to the porch, and laid her in the same place I had laid the body of Old Dan. I covered her with gunny sacks.

All through the night I would get up and check on her. Next morning I took warm fresh milk and again I opened her mouth and fed her. It was a miserable day for me. At noon it was the same. My dog had just given up. There was no will to live.

That evening when I came in from the fields, she was gone. I hurried to my mother. Mama told me she had seen her

go up the hollow from the house, so weak she could hardly stand. Mama had watched her until she had disappeared in the timber.

I hurried up the hollow, calling her name. I called and called. I went up to the head of it, still calling her name and praying she would come to me. I climbed out onto the flats; looking, searching, and calling. It was no use. My dog was gone.

I had a thought, a ray of hope. I just knew I'd find her at the grave of Old Dan. I hurried there.

I found her lying on her stomach, her hind legs stretched out straight, and her front feet folded back under her chest. She had laid her head on his grave. I saw the trail where she had dragged herself through the leaves. The way she lay there, I thought she was alive. I called her name. She made no movement. With the last ounce of strength in her body, she had dragged herself to the grave of Old Dan.

Kneeling down by her side, I reached out and touched her. There was no response, no whimpering cry or friendly wag of her tail. My little dog was dead.

I laid her head in my lap and with tear-filled eyes gazed up into the heavens. In a choking voice, I asked, "Why did they have to die? Why must I hurt so? What have I done wrong?"

I heard a noise behind me. It was my mother. She sat down and put her arm around me.

"You've done no wrong, Billy," she said. "I know this seems terrible and I know how it hurts, but at one time or another, everyone suffers. Even the Good Lord suffered while He was here on earth."

"I know, Mama," I said, "but I can't understand. It was bad enough when Old Dan died. Now Little Ann is gone. Both of them gone, just like that."

"Billy, you haven't lost your dogs altogether," Mama said. "You'll always have their memory. Besides, you can have some more dogs."

I rebelled at this. "I don't want any more dogs," I said. "I won't ever want another dog. They wouldn't be like Old Dan and Little Ann."

"We all feel that way, Billy," she said. "I do especially. They've fulfilled a prayer that I thought would never be answered."

"I don't believe in prayers any more," I said. "I prayed for my dogs, and now look, both of them are dead."

Mama was silent for a moment; then, in a gentle voice, she said, "Billy, sometimes it's hard to believe that things like this can happen, but there's always an answer. When you're older, you'll understand better."

"No, I won't," I said. "I don't care if I'm a hundred years old, I'll never understand why my dogs had to die."

As if she were talking to someone far away, I heard her say in a low voice, "I don't know what to say. I can't seem to find the right words."

Looking up to her face, I saw that her eyes were flooded with tears.

"Mama, please don't cry," I said. "I didn't mean what I said."

"I know you didn't," she said, as she squeezed me up tight. "It's just your way of fighting back."

I heard the voice of my father calling to us from the house.



"Come now," Mama said. "I have supper ready and your father wants to talk to you. I think when you've heard what he has to say, you'll feel better."

"I can't leave Little Ann like this, Mama," I said. "It'll be cold tonight. I think I'll carry her back to the house."

"No, I don't think you should do that," Mama said. "Your sisters would go all to pieces. Let's make her comfortable here."

Raking some dead leaves into a pile, she picked Little Ann up and laid her in them. Taking off my coat, I spread it over her body. I dreaded to think of what I had to do on the morrow.

My father and sisters were waiting for us on the porch. Mama told them the sad story. My sisters broke down and started crying. They ran to Mama and buried their faces in her long cotton dress.

Papa came over and laid his hand on my shoulder. "Billy," he said, "there are times in a boy's life when he has to stand up like a man. This is one of those times. I know what you're going through and how it hurts, but there's always an answer. The Good Lord has a reason for everything He does."

"There couldn't be any reason for my dogs to die, Papa," I said. "There just couldn't. They hadn't done anything wrong."

Papa glanced at Mama. Getting no help from her, he said, "It's getting cold out here. Let's go in the house. I have something to show you."

"Guess what we're having for supper," Mama said, as we turned to enter the house. "Your favorite, Billy, sweet potato pie. You'll like that, won't you?"

I nodded my head, but my heart wasn't in it.



Papa didn't follow us into the kitchen. He turned and entered his bedroom.

When he came into the room, he had a small shoe box in his hand. I recognized the box by the bright blue ribbon tied around it. Mama kept her valuables in it.

A silence settled over the room. Walking to the head of the table, Papa set the box down and started untying the ribbon. His hands were trembling as he fumbled with the knot. With the lid off, he reached in and started lifting out bundles of money.

After stacking them in a neat pile, he raised his head and looked straight at me. "Billy," he said, "you know how your mother has prayed that some day we'd have enough money to move out of these hills and into town so that you children could get an education."

I nodded my head.

"Well," he said, in a low voice, "because of your dogs, her prayers have been answered. This is the money earned by Old Dan and Little Ann. I've managed to make the farm feed us and clothe us and I've saved every cent your furs brought in. We now have enough."

"Isn't it wonderful," Mama said. "It's just like a miracle."

"I think it is a miracle," Papa said. "Remember, Billy said a prayer when he asked for his pups and then there were your prayers. Billy got his pups. Through those dogs your prayers were answered. Yes, I'm sure it is a miracle."

"If he gave them to me, then why did he take them away?" I asked.

"I think there's an answer for that, too," Papa said. "You

see, Billy, your mother and I had decided not to separate you from your dogs. We knew how much you loved them. We decided that when we moved to town we'd leave you here with your grandpa for a while. He needs help anyway. But I guess the Good Lord didn't want that to happen. He doesn't like to see families split up. That's why they were taken away."

I knew my father was a firm believer in fate. To him everything that happened was the will of God, and in his Bible he could always find the answers.

Papa could see that his talk had had very little effect on me. With a sorrowful look on his face, he sat down and said, "Now let us give thanks for our food and for all the wonderful things God has done for us. I'll say a special prayer and ask Him to help Billy."

I barely heard what Papa had to say.

During the meal, I could tell that no one was enjoying the food. As soon as it was over, I went to my room and lay down on the bed.

Mama came in. "Why don't you go to bed," she said, "and get a good night's sleep. You'll feel better tomorrow."

"No, I won't, Mama," I said. "I'll have to bury Little Ann tomorrow."

"I know," she said, as she turned my covers down. "I'll help if you want me to."

"No, Mama," I said, "I don't want anyone to help. I'd rather do it all by myself."

"Billy, you're always doing things by yourself," Mama said. "That's not right. Everyone needs help some time in his life."

"I know, Mama," I said, "but, please, not this time. Ever

since my dogs were puppies, we've always been together—just us three. We hunted together and played together. We even went swimming together.

“Did you know, Mama, that Little Ann used to come every night and peek in my window just to see if I was all right? I guess that's why I want to be by myself when I bury her.”

“Now say your prayers and go to sleep. I'm sure you'll feel better in the morning.”

I didn't feel like saying any prayers that night. I was hurting too much. Long after the rest of the family had gone to bed, I lay staring into the darkness, trying to think and not able to.

Some time in the night I got up, tiptoed to my window, and looked out at my doghouse. It looked so lonely and empty sitting there in the moonlight. I could see that the door was slightly ajar. I thought of the many times I had lain in my bed and listened to the squeaking of the door as my dogs went in and out. I didn't know I was crying until I felt the tears roll down my cheeks.

Mama must have heard me get up. She came in and put her arms around me. “Billy,” she said, in a quavering voice, “you'll just have to stop this. You're going to make yourself sick and I don't think I can stand any more of it.”

“I can't, Mama,” I said. “It hurts so much, I just can't. I don't want you to feel bad just because I do.”

“I can't help it, Billy,” she said. “Come now and get back in bed. I'm afraid you'll catch cold.”

After she had tucked me in, she sat on the bed for a while. As if she were talking to the darkness, I heard her say, “If only there were some way I could help—something I could do.”

"No one can help, Mama," I said. "No one can bring my dogs back."

"I know," she said, as she got up to leave the room, "but there must be something—there just has to be."

After Mama had left the room, I buried my face in my pillow and cried myself to sleep.

The next morning I made another box. It was smaller than the first one. Each nail I drove in the rough pine boards caused the knot in my throat to get bigger and bigger.

My sisters came to help. They stood it for a while, then with tears streaming, they ran for the house.

I buried Little Ann by the side of Old Dan. I knew that was where she wanted to be. I also buried a part of my life along with my dog.

Remembering a sandstone ledge I had seen while prowling the woods, I went there. I picked out a nice stone and carried it back to the graves. Then, with painstaking care, I carved their names deep in its red surface.

As I stood looking at the two graves, I tried hard to understand some of the things my father had told me, but I couldn't—I was still hurting and still had that empty feeling.

I went to Mama and had a talk with her.

"Mama," I asked, "do you think God made a heaven for all good dogs?"

"Yes," she said, "I'm sure He did."

"Do you think He made a place for dogs to hunt? You know—just like we have here on our place—with mountains and sycamore trees, rivers and cornfields, and old rail fences? Do you think He did?"

"From what I've read in the Good Book, Billy," she said, "He put far more things up there than we have here. Yes, I'm sure He did."

I was thinking this over when Mama came up to me and started tucking my shirt in. "Do you feel better now?" she asked.

"It still hurts, Mama," I said, as I buried my face in her dress, "but I do feel a little better."

"I'm glad," she said, as she patted my head. "I don't like to see my little boy hurt like this."



## TWENTY

THE FOLLOWING SPRING WE LEFT the Ozarks. The day we moved I thought everyone would be sad, but it was just the opposite. Mama seemed to be the happiest one of all. I could hear her laughing and joking with my sisters as they packed things. She had a glow in her eyes I had never seen before and it made me feel good.

I even noticed a change in Papa. He didn't have that whipped look on his face any more. He was in high spirits as we carried the furniture out to our wagon.

After the last item was stored in the wagon, Papa helped Mama to the spring seat and we were ready to go.

"Papa, would you mind waiting a few minutes?" I asked. "I'd like to say good-bye to my dogs."

"Sure," he said, smiling. "We have plenty of time. Go right ahead."

Nearing the graves, I saw something different. It looked like a wild bush had grown up and practically covered the two little mounds. It made me angry to think that an old bush would dare grow so close to the graves. I took out my knife, intending to cut it down.

When I walked up close enough to see what it was, I sucked in a mouthful of air and stopped. I couldn't believe what I was seeing. There between the graves, a beautiful red fern had sprung up from the rich mountain soil. It was fully two feet tall and its long red leaves had reached out in rainbow arches curved over the graves of my dogs.

I had heard the old Indian legend about the red fern. How a little Indian boy and girl were lost in a blizzard and had frozen to death. In the spring, when they were found, a beautiful red fern had grown up between their two bodies. The story went on to say that only an angel could plant the seeds of a red fern, and that they never died; where one grew, that spot was sacred.

Remembering the meaning of the legend, I turned and started hollering for Mama.

"Mama! Mama!" I shouted. "Come here! And hurry! You won't believe it."

In a frightened voice, she shouted back, "What is it, Billy? Are you all right?"

"I'm all right, Mama," I shouted, "but hurry. You just won't believe it."

Holding her long skirt in her hand and with a frightened look on her face, Mama came puffing up the hillside. Close behind her came Papa and my sisters.

"What is it, Billy?" Mama asked, in a scared voice. "Are you all right?"

"Look!" I said, pointing at the red fern.

Staring wide-eyed, Mama gasped and covered her mouth with her hand. I heard her say, almost in a whisper, "Oh-h-h-h, it's a red fern—a sacred red fern."

She walked over and very tenderly started fingering the long red leaves. In an awed voice, she said, "All my life I've wanted to see one. Now I have. It's almost unbelievable."

"Don't touch it, Mama," my oldest sister whispered. "It was planted by an angel."

Mama smiled and asked, "Have you heard the legend?"

"Yes, Mama," my sister said. "Grandma told me the story, and I believe it, too."

With a serious look on his face, Papa said, "These hills are full of legends. Up until now I've never paid much attention to them, but now I don't know. Perhaps there is something to the legend of the red fern. Maybe this is God's way of helping Billy understand why his dogs died."

"I'm sure it is, Papa," I said, "and I do understand. I feel different now, and I don't hurt any more."

"Come," Mama said, "let's go back to the wagon. Billy wants to be alone with his dogs for a while."

Just as they turned to leave, I heard Papa murmur in a low voice, "Wonderful indeed is the work of our Lord."

As I stood looking at the two graves, I noticed things I hadn't seen before. Wild violets, rooster heads, and mountain daisies had completely covered the two little mounds. A summer breeze gushed down from the rugged hills. I felt its warm

caress as it fanned my face. It hummed a tune in the underbrush and rustled the leaves on the huge red oak. The red fern wavered and danced to the music of the hills.

Taking off my cap, I bowed my head. In a choking voice, I said, "Good-bye, Old Dan and Little Ann. I'll never forget you; and this I know—if God made room in heaven for all good dogs, I know He made a special place for you."

With a heavy heart, I turned and walked away. I knew that as long as I lived I'd never forget the two little graves and the sacred red fern.

Not far from our home, the road wound its way up and over a hill. At the top Papa stopped the team. We all stood up and looked back. It was a beautiful sight, one I'll never forget.

As I stood and looked at the home of my birth, it looked sad and lonely. There was no spiral of lazy blue smoke twisting from the rock chimney, no white leghorn hen chasing a June bug, no horse or cow standing with head down and tail switching.

I saw I had left the door to the barn loft open. A tuft of hay hung out. It wavered gently in the warm summer breeze.

Something scurried across the vacant yard and disappeared under the barn. It was Samie, our house cat. I heard my little sister say in a choking voice, "Mommie, we forgot Samie."

There was no answer.

To the left, I could see our fields and the zigzag lines of rail fences. Farther down, I could see the shimmering whiteness of the tall sycamores. My vision blurred as tears came to my eyes.

The sorrowful silence was broken by my mother's voice. She asked, "Billy, can you see it?"

"See what, Mama?" I asked.

"The red fern," she said.

My oldest sister spoke up. "I can see it," she said.

Rubbing my eyes, I looked to the hillside above our home. There it stood in all its wild beauty, a waving red banner in a carpet of green. It seemed to be saying, "Good-bye, and don't worry, for I'll be here always."

Hearing a sniffing, I turned around. My three little sisters had started crying. Mama said something to Papa. I heard the jingle of the trace chains as they tightened in the singletrees.

Our wagon moved on.

I have never been back to the Ozarks. All I have left are my dreams and memories, but if God is willing, some day I'd like to go back—back to those beautiful hills. I'd like to walk again on trails I walked in my boyhood days.

Once again I'd like to face a mountain breeze and smell the wonderful scent of the redbuds, and papaws, and the dogwoods. With my hands I'd like to caress the cool white bark of a sycamore.

I'd like to take a walk far back in the flinty hills and search for a souvenir, an old double-bitted ax stuck deep in the side of a white oak tree. I know the handle has long since rotted away with time. Perhaps the rusty frame of a coal-oil lantern still hangs there on the blade.

I'd like to see the old home place, the barn and the rail fences. I'd like to pause under the beautiful red oaks where my sisters and I played in our childhood. I'd like to walk up the hillside to the graves of my dogs.

I'm sure the red fern has grown and has completely covered



the two little mounds. I know it is still there, hiding its secret beneath those long, red leaves, but it wouldn't be hidden from me for part of my life is buried there, too.

Yes, I know it is still there, for in my heart I believe the legend of the sacred red fern.

$\begin{array}{r} 12 \\ \times 2 \\ \hline 24 \end{array}$	$\begin{array}{r} 2 \\ \times 12 \\ \hline 24 \end{array}$	$\begin{array}{r} 12 \\ \times 7 \\ \hline 84 \end{array}$	$\begin{array}{r} 7 \\ \times 12 \\ \hline 84 \end{array}$	$\begin{array}{r} 12 \\ \times 5 \\ \hline 60 \end{array}$	$\begin{array}{r} 12 \\ \times 9 \\ \hline 108 \end{array}$	$\begin{array}{r} 12 \\ \times 12 \\ \hline 144 \end{array}$	$\begin{array}{r} 10 \\ \times 12 \\ \hline 120 \end{array}$	$\begin{array}{r} 11 \\ \times 9 \\ \hline 99 \end{array}$	$\begin{array}{r} 2 \\ \times 11 \\ \hline 22 \end{array}$
--	--	--	--	--	---	--	--	--	--

$$\begin{array}{r} 5 \\ \times 12 \\ \hline 60 \end{array}$$

$$\begin{array}{r} 7 \\ \times 12 \\ \hline 84 \end{array}$$

$$\begin{array}{r} 9 \\ \times 12 \\ \hline 108 \end{array}$$

$$\begin{array}{r} 5 \\ \times 12 \\ \hline 60 \end{array}$$

$$\begin{array}{r} 12 \\ \times 2 \\ \hline 24 \end{array}$$

$$\begin{array}{r} 12 \\ \times 7 \\ \hline 84 \end{array}$$

$$\begin{array}{r} 9 \\ \times 12 \\ \hline 108 \end{array}$$

$$\begin{array}{r} 2 \\ \times 12 \\ \hline 24 \end{array}$$

$$\begin{array}{r} 12 \\ \times 12 \\ \hline 144 \end{array}$$

$$\begin{array}{r} 7 \\ \times 12 \\ \hline 84 \end{array}$$

**One-Minute Test**

Goal  Completed

$\begin{array}{r} 12 \\ \times 12 \\ \hline 144 \end{array}$	$\begin{array}{r} 12 \\ \times 1 \\ \hline 12 \end{array}$	$\begin{array}{r} 11 \\ \times 3 \\ \hline 33 \end{array}$	$\begin{array}{r} 4 \\ \times 11 \\ \hline 44 \end{array}$	$\begin{array}{r} 10 \\ \times 8 \\ \hline 80 \end{array}$	$\begin{array}{r} 12 \\ \times 2 \\ \hline 24 \end{array}$	$\begin{array}{r} 7 \\ \times 10 \\ \hline 70 \end{array}$
$\begin{array}{r} 12 \\ \times 9 \\ \hline 108 \end{array}$	$\begin{array}{r} 10 \\ \times 12 \\ \hline 120 \end{array}$	$\begin{array}{r} 6 \\ \times 10 \\ \hline 60 \end{array}$	$\begin{array}{r} 3 \\ \times 10 \\ \hline 30 \end{array}$	$\begin{array}{r} 11 \\ \times 4 \\ \hline 44 \end{array}$	$\begin{array}{r} 12 \\ \times 7 \\ \hline 84 \end{array}$	$\begin{array}{r} 7 \\ \times 11 \\ \hline 77 \end{array}$
$\begin{array}{r} 10 \\ \times 9 \\ \hline 90 \end{array}$	$\begin{array}{r} 12 \\ \times 9 \\ \hline 108 \end{array}$	$\begin{array}{r} 12 \\ \times 7 \\ \hline 84 \end{array}$	$\begin{array}{r} 2 \\ \times 12 \\ \hline 24 \end{array}$	$\begin{array}{r} 5 \\ \times 12 \\ \hline 60 \end{array}$	$\begin{array}{r} 6 \\ \times 11 \\ \hline 66 \end{array}$	$\begin{array}{r} 12 \\ \times 2 \\ \hline 24 \end{array}$
$\begin{array}{r} 12 \\ \times 5 \\ \hline 60 \end{array}$	$\begin{array}{r} 8 \\ \times 11 \\ \hline 88 \end{array}$	$\begin{array}{r} 9 \\ \times 11 \\ \hline 99 \end{array}$	$\begin{array}{r} 5 \\ \times 11 \\ \hline 55 \end{array}$	$\begin{array}{r} 1 \\ \times 12 \\ \hline 12 \end{array}$	$\begin{array}{r} 10 \\ \times 6 \\ \hline 60 \end{array}$	$\begin{array}{r} 3 \\ \times 11 \\ \hline 33 \end{array}$
$\begin{array}{r} 10 \\ \times 3 \\ \hline 30 \end{array}$	$\begin{array}{r} 10 \\ \times 1 \\ \hline 10 \end{array}$	$\begin{array}{r} 4 \\ \times 10 \\ \hline 40 \end{array}$	$\begin{array}{r} 11 \\ \times 8 \\ \hline 88 \end{array}$	$\begin{array}{r} 12 \\ \times 10 \\ \hline 120 \end{array}$	$\begin{array}{r} 2 \\ \times 11 \\ \hline 22 \end{array}$	$\begin{array}{r} 11 \\ \times 10 \\ \hline 110 \end{array}$
$\begin{array}{r} 11 \\ \times 7 \\ \hline 77 \end{array}$	$\begin{array}{r} 10 \\ \times 12 \\ \hline 120 \end{array}$	$\begin{array}{r} 11 \\ \times 2 \\ \hline 22 \end{array}$	$\begin{array}{r} 10 \\ \times 7 \\ \hline 70 \end{array}$	$\begin{array}{r} 2 \\ \times 10 \\ \hline 20 \end{array}$	$\begin{array}{r} 12 \\ \times 11 \\ \hline 132 \end{array}$	$\begin{array}{r} 12 \\ \times 10 \\ \hline 120 \end{array}$
$\begin{array}{r} 10 \\ \times 10 \\ \hline 100 \end{array}$	$\begin{array}{r} 2 \\ \times 2 \\ \hline 4 \end{array}$	$\begin{array}{r} 11 \\ \times 11 \\ \hline 121 \end{array}$	$\begin{array}{r} 8 \\ \times 10 \\ \hline 80 \end{array}$	$\begin{array}{r} 11 \\ \times 9 \\ \hline 99 \end{array}$	$\begin{array}{r} 1 \\ \times 11 \\ \hline 11 \end{array}$	$\begin{array}{r} 7 \\ \times 12 \\ \hline 84 \end{array}$
$\begin{array}{r} 10 \\ \times 11 \\ \hline 110 \end{array}$	$\begin{array}{r} 10 \\ \times 4 \\ \hline 40 \end{array}$	$\begin{array}{r} 12 \\ \times 9 \\ \hline 108 \end{array}$	$\begin{array}{r} 11 \\ \times 1 \\ \hline 11 \end{array}$	$\begin{array}{r} 5 \\ \times 10 \\ \hline 50 \end{array}$	$\begin{array}{r} 9 \\ \times 10 \\ \hline 90 \end{array}$	$\begin{array}{r} 1 \\ \times 10 \\ \hline 10 \end{array}$

$$\begin{array}{r} 12 \\ \times 10 \\ \hline 120 \end{array}$$

$$\begin{array}{r} 12 \\ \times 2 \\ \hline 24 \end{array}$$

$$\begin{array}{r} 12 \\ \times 5 \\ \hline 60 \end{array}$$

$$\begin{array}{r} 12 \\ \times 7 \\ \hline 84 \end{array}$$

$$\begin{array}{r} 2 \\ \times 12 \\ \hline 24 \end{array}$$

$$\begin{array}{r} 2 \\ \times 10 \\ \hline 20 \end{array}$$

$$\begin{array}{r} 12 \\ \times 9 \\ \hline 108 \end{array}$$

$$\begin{array}{r} 7 \\ \times 12 \\ \hline 84 \end{array}$$

$$\begin{array}{r} 9 \\ \times 12 \\ \hline 108 \end{array}$$

$$\begin{array}{r} 12 \\ \times 7 \\ \hline 84 \end{array}$$

$$\begin{array}{r} 12 \\ \times 2 \\ \hline 24 \end{array}$$

$$\begin{array}{r} 12 \\ \times 9 \\ \hline 108 \end{array}$$

$$\begin{array}{r} 2 \\ \times 12 \\ \hline 24 \end{array}$$

$$\begin{array}{r} 12 \\ \times 5 \\ \hline 60 \end{array}$$

$$\begin{array}{r} 11 \\ \times 4 \\ \hline 44 \end{array}$$

$$\begin{array}{r} 1 \\ \times 10 \\ \hline 10 \end{array}$$

$$\begin{array}{r} 5 \\ \times 12 \\ \hline 60 \end{array}$$

$$\begin{array}{r} 12 \\ \times 10 \\ \hline 120 \end{array}$$

## Monday Math Answer Key

1. Label the number line below to show the integers between (-7) and 3.

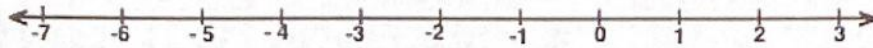

2. Arrange the numbers in order, beginning with the greatest (-11), 8, (-6), 11.

11, 8, (-6), (-11)

### Adding Positive Integers

3. Add  $2 + 5$  on the number line.

$$2 + 5 = 7$$

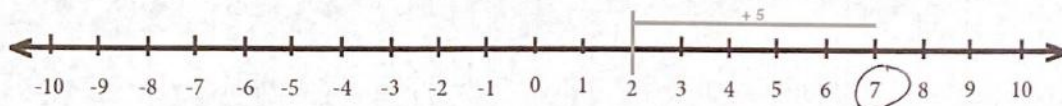

### Adding Negative Integers

4. Add  $(-3) + (-4)$  on the number line.

$$(-3) + (-4) = (-7)$$

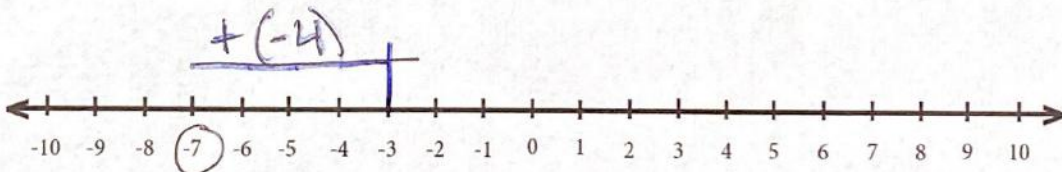

5. Add  $(-7)$  and  $(-9)$  on the number line.

$$(-7) + (-9) = (-16)$$

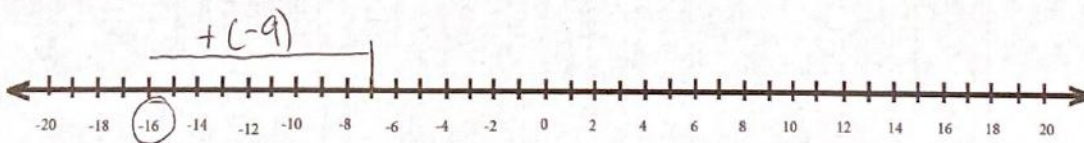

6.  $(-6) + (-14) = (-20)$

7.  $(-42) + (-18) = (-60)$

8.  $(-25) + (-119) = (-144)$

### Adding a Positive and a Negative Integer

9. Add  $(-2) + (8)$  on a number line.

$$(-2) + (8) = 6$$

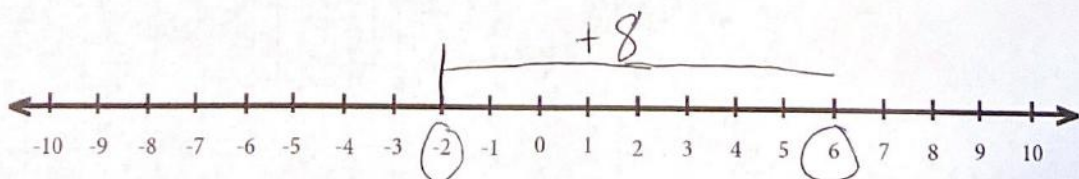

10. Add  $17 + (-19)$  on a number line.  $17 + (-19) = (-2)$

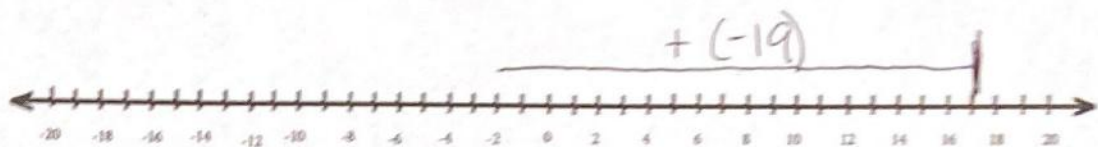

11.  $(-8) + 11 = 3$

12.  $(-78) + 45 = (-33)$

13.  $100 + (-55) = 45$

### Tuesday Math Answer Key

1. Graph the equation  $y = 3 + x$ .

a. Complete this input-output table for the equation  $y = 3 + x$ .

x	-4	(-3)	(-2)	(-1)	0	1
y	(-1)	0	1	2	3	4
(x, y)	(-4, -1)	(-3, 0)	(-2, 1)	(-1, 2)	(0, 3)	(1, 4)

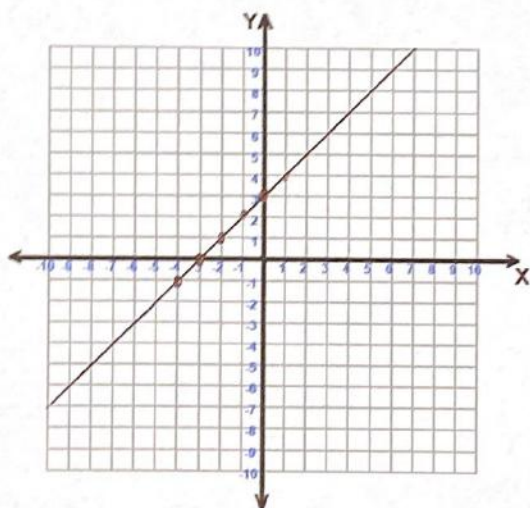

Checklist for a good line on a coordinate graph.

- It's straight!
- It goes through all of the points!
- It extends past those points.

Try to fix your graph if it is incorrect.



2. Graph the equation  $y = (-2) + x$ .

x	-4	(-3)	(-2)	(-1)	0	1
y	(-6)	(-5)	(-4)	(-3)	(-2)	(-1)
(x, y)	(-4, -6)	(-3, -5)	(-2, -4)	(-1, -3)	(0, -2)	(1, -1)

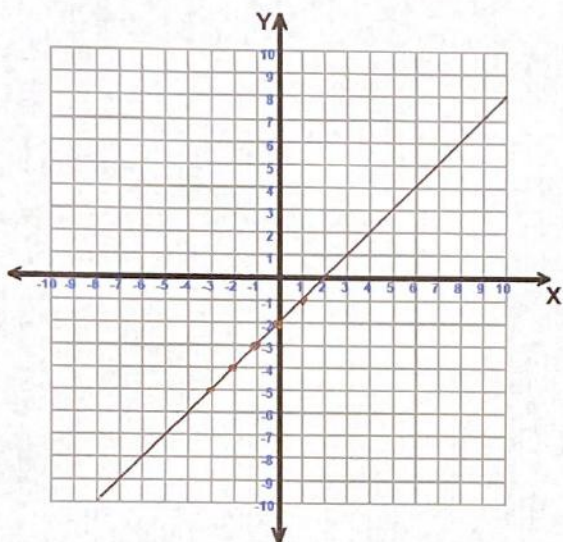

Checklist for a good line on a coordinate graph.

- It's straight!
- It goes through all of the points!
- It extends past those points.

Try to fix your graph if it is incorrect.

3. Graph the equation  $y = (-5) + x$ .

x	-2	(-1)	0	1	2	3
y	(-7)	(-6)	(-5)	(-4)	(-3)	(-2)
(x, y)	(-2, -7)	(-1, -6)	(0, -5)	(1, -4)	(2, -3)	(3, -2)

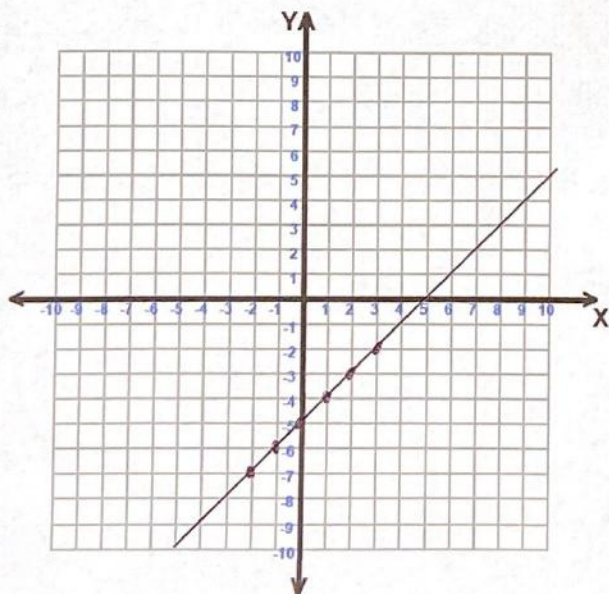

Checklist for a good line on a coordinate graph.

- It's straight!
- It goes through all of the points!
- It extends past those points.

Try to fix your graph if it is incorrect.



### Wednesday Math Answer Key

Find the unknown marked angle in the following triangles. Show your work using the inverse operation method or the number bond method.

1. The missing angle is angle  $q$ . Find the value of angle  $q$ .

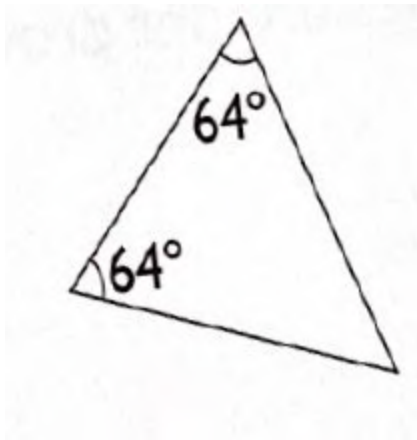

$$q + 64 + 64 = 180$$

$$q + 128 = 180$$

$$q = 180 - 128$$

$$q = 52 \text{ degrees}$$

2. Find the value of angle  $CAB$ .

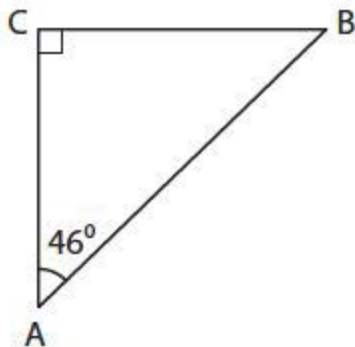

$$CBA + 90 + 46 = 180$$

$$CBA + 136 = 180$$

$$CBA = 180 - 136$$

$$CBA = 44 \text{ degrees}$$

3. Find the value of angle  $XYZ$ .

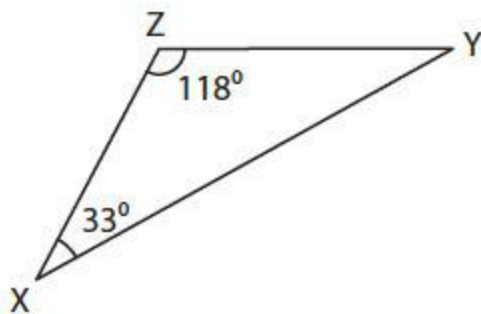

$$XYZ + 33 + 118 = 180$$

$$XYZ + 151 = 180$$

$$XYZ = 180 - 151$$

$$XYZ = 29 \text{ degrees}$$

Find the unknown marked angle in the following quadrilaterals.

4. Find the value of angle x.

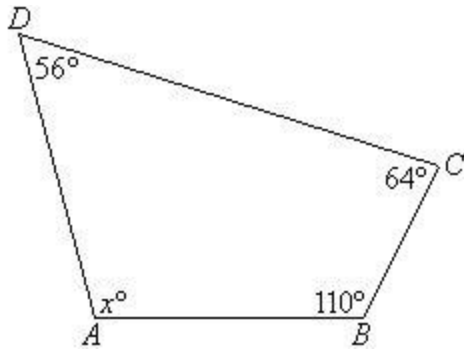

$$x + 56 + 64 + 110 = 360$$

$$x + 120 + 110 = 360$$

$$x + 230 = 360$$

$$x = 360 - 230$$

$$x = 130 \text{ degrees}$$

5. Find the value of angle BAD.

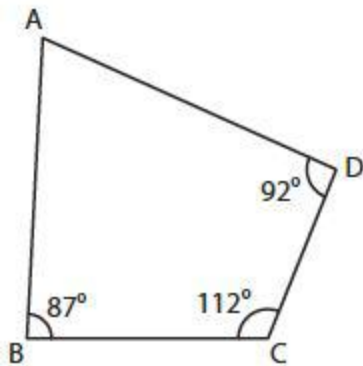

$$BAD + 92 + 112 + 87 = 360$$

$$BAD + 204 + 87 = 360$$

$$BAD + 291 = 360$$

$$BAD = 360 - 291$$

$$BAD = 69 \text{ degrees}$$

6. Find the value of angle PQR.

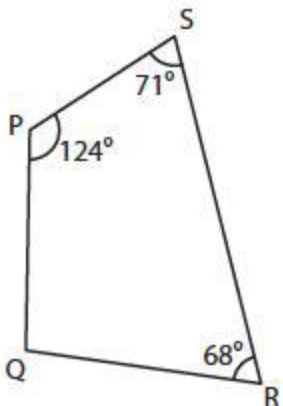

$$PQR + 124 + 71 + 68 = 360$$

$$PQR + 195 + 68 = 360$$

$$PQR + 263 = 360$$

$$PQR = 360 - 263$$

$$PQR = 97 \text{ degrees}$$

### Review Adding Integers

7.  $(-9) + (-2) = (-11)$
8.  $(-9) + 2 = (-7)$
9.  $9 + (-2) = 7$
10.  $9 + (-12) = (-3)$
11.  $27 + 45 = 72$
12.  $45 + (-14) = 31$
13.  $(-45) + 54 = 9$
14.  $100 + (-101) = (-1)$
15.  $100 + (-100) = 0$

### Adding Negative Integers

1. Add  $(-6)$  and  $(-2)$  using the number line.

$$(-6) + (-2) = (-8)$$

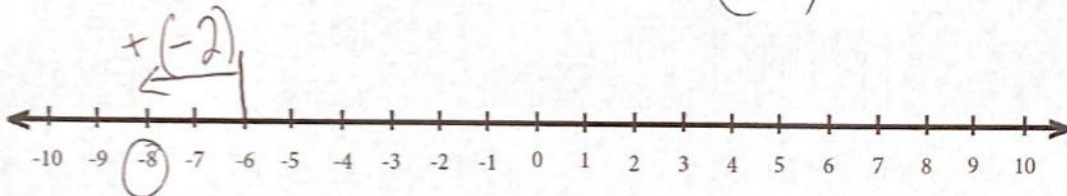

2. Add  $(-14)$  and  $(-5)$  using the number line.

$$(-14) + (-5) = (-19)$$

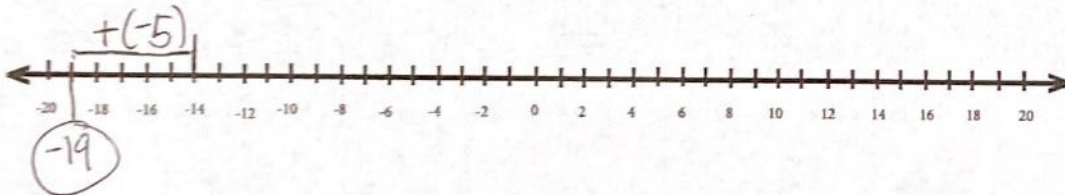

### Adding Positive and Negative Integers

3. Add  $(-9)$  and  $8$  using the number line.

$$(-9) + 8 = (-1)$$

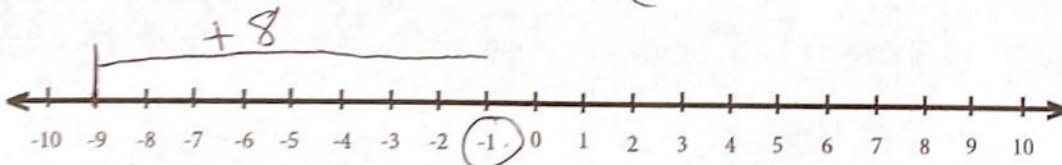

4. Add  $14$  and  $(-7)$  using the number line.

$$14 + (-7) = 7$$

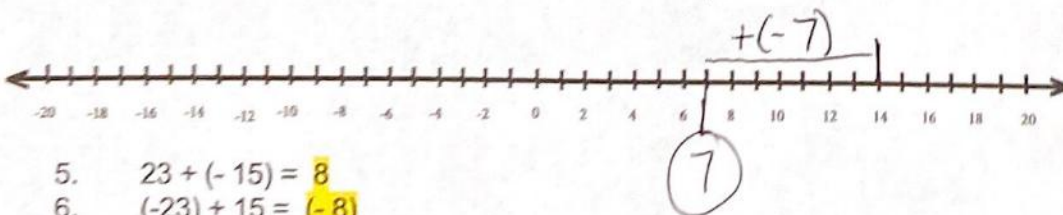

5.  $23 + (-15) = 8$
6.  $(-23) + 15 = (-8)$
7.  $100 + (-58) = 42$
8.  $58 + (-100) = (-42)$
9.  $(-21) + (-12) + 9 = (-33) + 9 = (-24)$



## Graphing a Linear Equation

10. Use the following input-output table to graph the equation  $y = x - 7$  on the coordinate plane below. Don't forget to make a straight line!

$x$	(-3)	(-2)	0	1	2	3	4
$y$	(-10)	(-9)	(-7)	(-6)	(-5)	(-4)	(-3)
$(x, y)$	(-3, -10)	(-2, -9)	(0, -7)	(1, -6)	(2, -5)	(3, -4)	(4, -3)

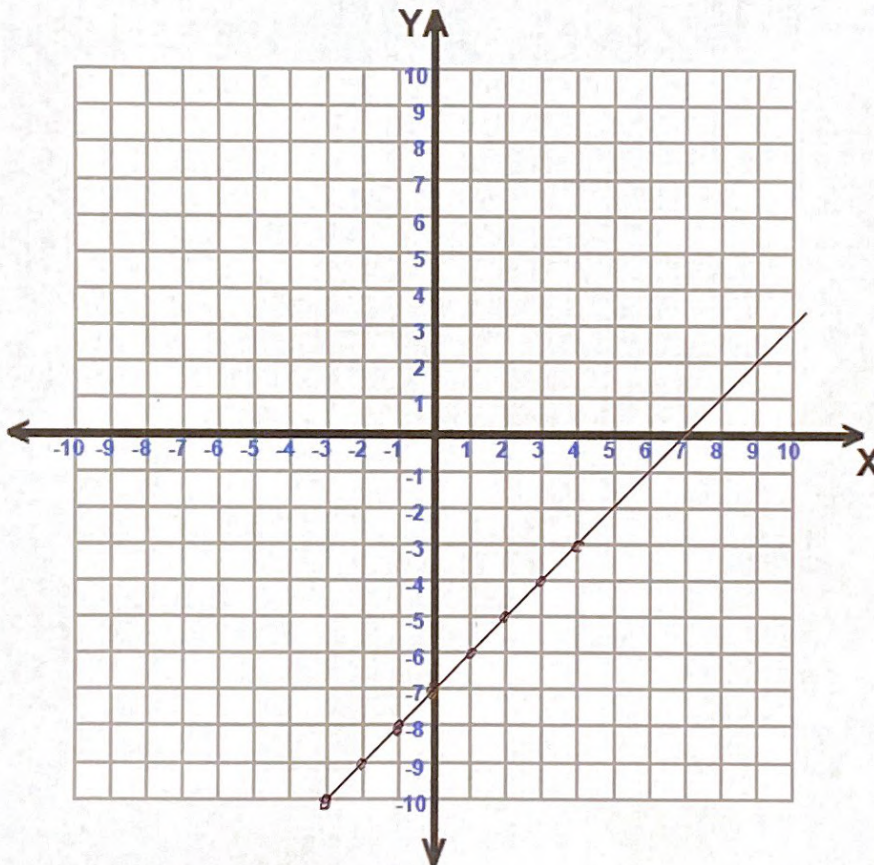

Checklist for a good line on a coordinate graph.

- It's straight!
- It goes through all of the points!
- It extends past those points.

## Finding Unknown Angles in Triangles

10. What is the sum of the angles in a triangle? **180** degrees

11. Find the value of the following unknown angles. Show your work using the inverse operation strategy or the number bond strategy.

a) Find the value of angle TUS.

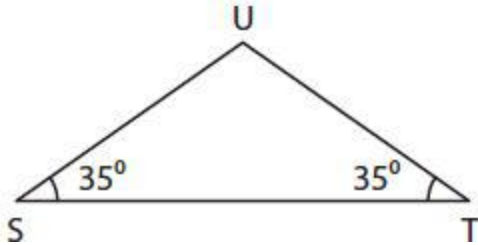

$$TUS + 35 + 35 = 180$$

$$TUS + 70 = 180$$

$$TUS = 180 - 70$$

$$TUS = 110 \text{ degrees}$$

b) Find the value of angle WVU.

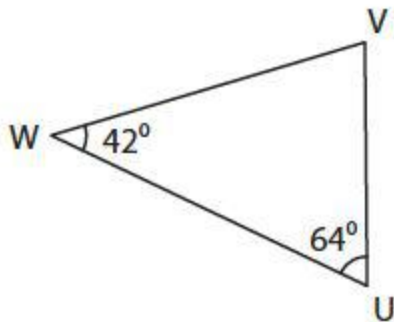

$$WVU + 42 + 64 = 180$$

$$WVU + 106 = 180$$

$$WVU = 180 - 106$$

$$WVU = 74 \text{ degrees}$$

c) Find the value of angle y.

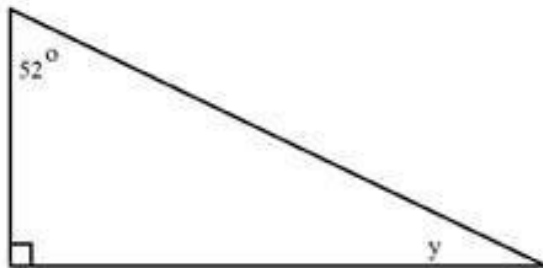

$$y + 52 + 90 = 180$$

$$y + 142 = 180$$

$$y = 180 - 142$$

$$y = 38 \text{ degrees}$$



## Finding Unknown Angles in Quadrilaterals

12. What is the sum of the angles in a quadrilateral? 360 degrees
13. What is the value of angle A?

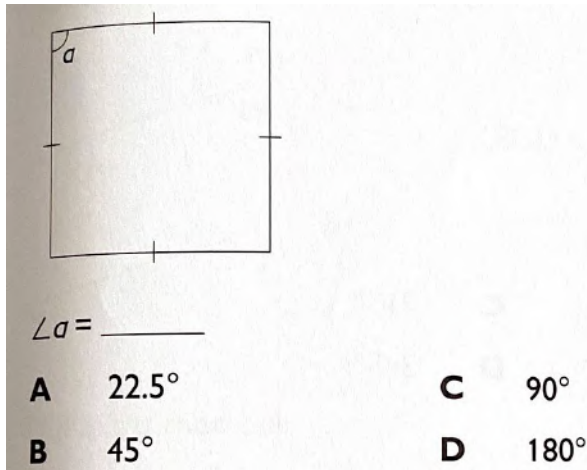

C or 90 degrees is the correct answer!

14. Find the value of the angles in the following quadrilaterals. Show your work using either the inverse operation strategy or the number bond strategy.

<p>a) Find the value of angle EFG.</p> <p><math>EFG + 75 + 146 + 91 = 360</math>  <math>EFG + 221 + 91 = 360</math>  <math>EFG + 312 = 360</math>  <math>EFG = 360 - 312</math>  <math>EFG = 48 \text{ degrees}</math></p>	<p>b) Find the value of angle WXU.</p> <p><math>WXU + 67 + 135 + 105 = 360</math>  <math>WXU + 202 + 105 = 360</math>  <math>WXU + 307 = 360</math>  <math>WXU = 360 - 307</math>  <math>WXU = 53 \text{ degrees}</math></p>
--	--